



MEAN WELL

SWITCHING POWER SUPPLY
ISO-9001 CERTIFIED MANUFACTURER

PD-45 SERIES

- .LOW COST, HIGH RELIABILITY
- .105°C OUTPUT CAPACITOR
- .INTERNATIONAL AC INPUT RANGE
- .HIGH EFFICIENCY, LOW WORKING TEMPERATURE
- .SOFT-START CIRCUIT, LIMITING AC SURGE CURRENT
- .SHORT CIRCUIT, OVERLOAD, OVER VOLTAGE PROTECTED
- .COMPACT SIZE, LIGHT WEIGHT
- .100% FULL LOAD BURN-IN TEST
- .BUILT IN EMI FILTER, LOW RIPPLE NOISE



SPECIFICATION	PD-45A		PD-45B	
	CH1	CH2	CH1	CH2
DC OUTPUT VOLTAGE	5V	12V	5V	24V
OUTPUT V. TOLERANCE	±4%	±7%	±4%	±7%
OUTPUT RATED CURRENT	3.2A	2A	3.2A	1.2A
OUTPUT MIN. CURRENT	0.4A	0.2A	0.4A	0.2A
OUTPUT MAX. CURRENT	5A	2.5A	5A	1.8A
RIPPLE & NOISE	50mVp-p	120mVp-p	50mVp-p	150mVp-p
LINE REGULATION	±1%	±2%	±1%	±2%
LOAD REGULATION	±3%	±4%	±3%	±4%
RATED OUTPUT POWER	40W		44.8W	
MAXIMUM OUTPUT POWER	RATED OUTPUT POWER FOR CONVECTION; 52W WITH 18 CFM MIN. FORCED AIR			
EFFICIENCY	77%		78%	
DC VOLTAGE ADJ.	CH1: +10,-5%		CH1: +10,-5%	
INPUT VOLTAGE RANGE	90~264VAC 47~440Hz ; 120~370VDC			
AC CURRENT	1A/115V 0.7A/230V			
INRUSH CURRENT	COLD START 20A/115V 40A/230V			
LEAKAGE CURRENT	<0.5 mA			
OVERLOAD PROTECTION	53~75W OUTPUT POWER TYPE:PLUSING HICCUP SHUTDOWN RESET:AUTO RECOVERY			
OVER VOLTAGE PROTECTION	5.75~6.75VDC ON CH1			
TEMP. COEFFICIENT	±0.04% / °C (0~50°C) ON +5V OUTPUT			
SETUP, RISE, HOLD UP TIME	800ms, 20ms, 20ms			
VIBRATION	10~500Hz, 2G 10min./1cycle, PERIOD FOR 60min. EACH AXES			
WITHSTAND VOLTAGE	I/P-O/P:3KVAC I/P-FG:1.5KVAC O/P-FG:0.5KVAC			
ISOLATION RESISTANCE	I/P-O/P, I/P-FG, O/P-FG:500VDC / 100M Ohms			
WORKING TEMP., HUMIDITY	-10°C~+60°C(REFER TO OUTPUT DERATING CURVE), 20%~90% RH			
STORAGE TEMP., HUMIDITY	-20°C~+85°C, 10%~95% RH			
DIMENSION	127*76.2*30mm (L*W*H) PCB ONLY			
WEIGHT	0.23Kgs			
SAFETY STANDARDS	UL1950, TUV EN60950 APPROVED			
EMC STANDARDS	CISPR22 (EN55022), IEC1000-4-2,3,4,5 IEC1000-3-2,3 VERIFICATION			

- NOTE :
- 1.ALL PARAMETERS ARE SPECIFIED AT 230VAC INPUT, RATED LOAD, 25°C 70% RH. AMBIENT.
 - 2.TOLERANCE GINCLUDE SET UP TOLERANCE, LINE REGULATION, LOAD REGULATION.
 - 3.RIPPLE & NOISE ARE MEASURED AT 20MHz BY USING A 12" TWISTED PAIR TERMINATED WITH A 0.1uF & 47uF CAPACITOR.
 - 4.LINE REGULATION IS MEASURED FROM LOW LINE TO HIGH LINE AT RATED LOAD.
 - 5.OUTPUT PROVIDE UP TO MAXIMUM CURRENT, BUT RELATED TO MAXIMUM OUTPUT POWER.
 - 6.EACH OUTPUT PROVIDE UP TO MAXIMUM CURRENT, BUT TOTAL LOAD CAN NOT EXCEED MAX. OUTPUT POWER.
 - 7.MOUNTING HOLES M1 AND M2 SHOULD BE GROUNDED FOR EMI PURPOSES.

DEC.28.98

BLOCK DIAGRAM

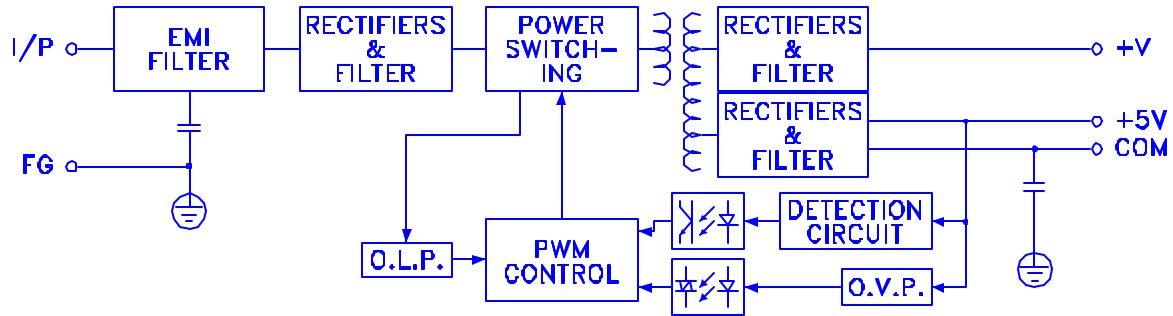

fosc : 65KHz

OUTPUT DERATING

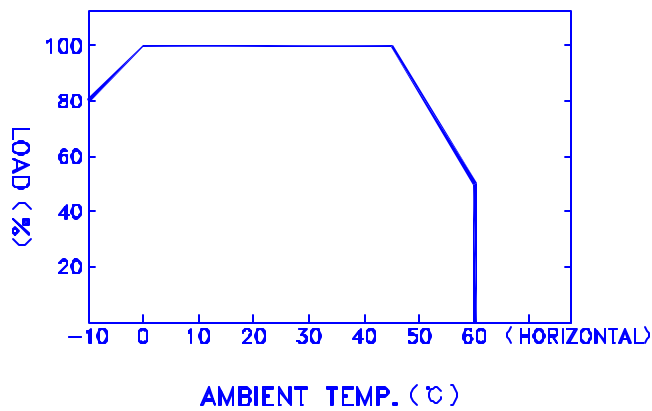

STATIC CHARACTERISTICS

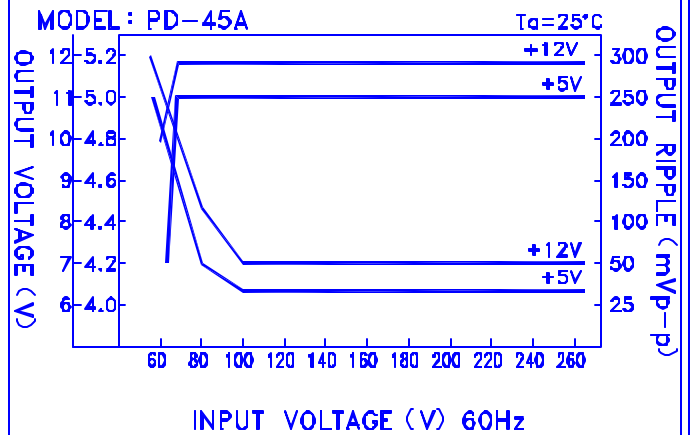

DIMENSION (mm)

☒ TERMINAL PIN NO. ASSIGNMENT

- ☒ CN1 : MOLEX 5277-02
PIN 1,2 : AC INPUT
- ☒ CN2 : MOLEX 5273-06
PIN 1 : DC OUTPUT +V
PIN 2,3 : DC OUTPUT +5V
PIN 4,5 : DC OUTPUT COM
PIN 6 : DC OUTPUT N.C.

☒ MATING CONNECTORS

- ☒ CN1,2 MATING CONNECTOR TYPE
MOLEX 5195 AND 5239 SERIES
OR EQUIVALENT WITH MOLEX
5194 AND 5225 OR EQUIVALENT
CRIMP TERMINALS.

