

- NOTES**
- MATERIALS:**  
HOUSING-PBT 30%GF UL94V-0.  
CONTACT-PHOSPHOR BRONZE, C5191R-H T=0.6mm.
  - FLASH: 0.25mm MAX.
  - CAMBER: 0.13mm MAX. DEFORMATION: NA.  
WARP: 0.13mm MAX TWIST: NA

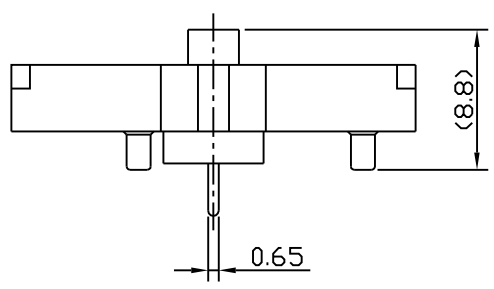

BTH-D-xx-LF  
LEADFREE

RoHS-Compliant

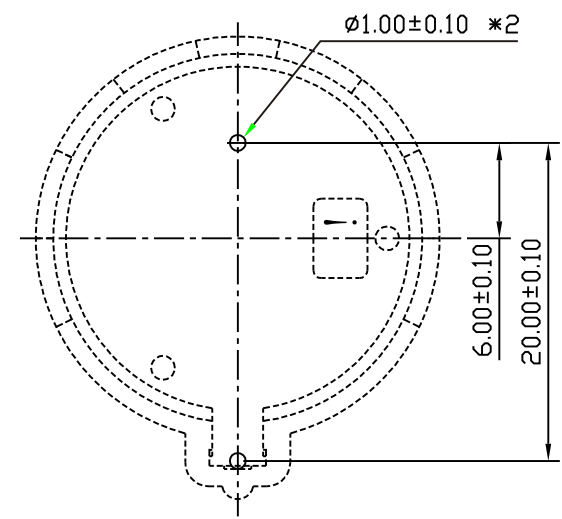

RECOMMEND PCB LAYOUT  
COMPONENT SIDE

PART NO	$\phi A$	B
BTH-D-20	22.8	27.8
BTH -D-23	25.4	29.0

«Промэлектроника»	PART NO. BTH-D-xx		CHECKED BY CY	TOLERANCES ARE .X ± 0.2 .XX ± .XXX ± AWG	DESCRIPTION: <b>BATTERY HOLDER ASS'Y</b>	AREA	REVISIONS	HK	DATE
	DWG NO. BTH-D-xx								
pr@promelec.ru	FILE NO.		PROJECTION						
	UNIT / mm	SCALE 1:1							